

Modell / Model	SCF 550 DE
Funktion / function	flach, rund / flat, cylindrical
Max. Rahmenformat / max. frame size ca.	550 x 750 x 30 mm
Max. Druckformat flach / max. printing area flat ca.	500 x 300 mm
Max. Druckformat rund / max. printing area round	∅ 170 x 300 mm
Max. Objekthöhe / max. product height ca.	200 mm
Geschwindigkeit / max. speed ca.	800 cycles / h
Dimension (L x W x H) ca.	820 x 908 x 1798 mm
Gewicht / weight ca.	350 kg
Druckluftanschluss / compressed air connection	6 bar
Luftverbrauch / air consumption Liter / min ca.	160
Anschlussspannung / power supply	230 V / 50 Hz 20 W

**SCF 550 DE**  
als Flachdruckmaschine  
as flat printing machine

CE

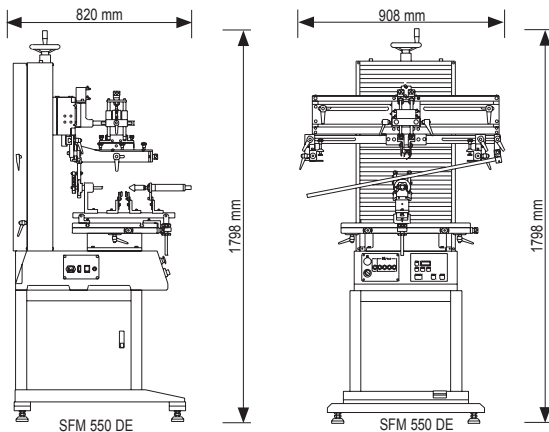

Modell / Model	SFM 550 DE
Funktion / function	flach / flat Motorischer Rakelantrieb / squeegee electr. driven
Max. Rahmenformat / max. frame size ca.	500 x 750 mm
Max. Druckformat flach / max. printing area flat ca.	500 x 300 mm
Max. Objekthöhe / max. product height ca.	200 mm
Geschwindigkeit / max. speed ca.	800 cycles / h
Dimension (L x W x H) ca.	820 x 908 x 1798 mm
Gewicht / weight ca.	240 kg
Druckluftanschluss / compressed air connection	6 bar
Luftverbrauch / air consumption Liter / min ca.	80
Anschlussspannung / power supply	230 V / 50 Hz 150 W



**SFM 550 DE**  
als Flachdruckmaschine  
as flat printing machine

CE